

OPTIONAL SUPPLIED
NOT MOUNTED
OPTIONAL FORNITO
NON MONTATO

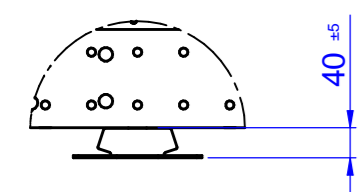

DETTAGLIO A

POSITIONING SCHEMA

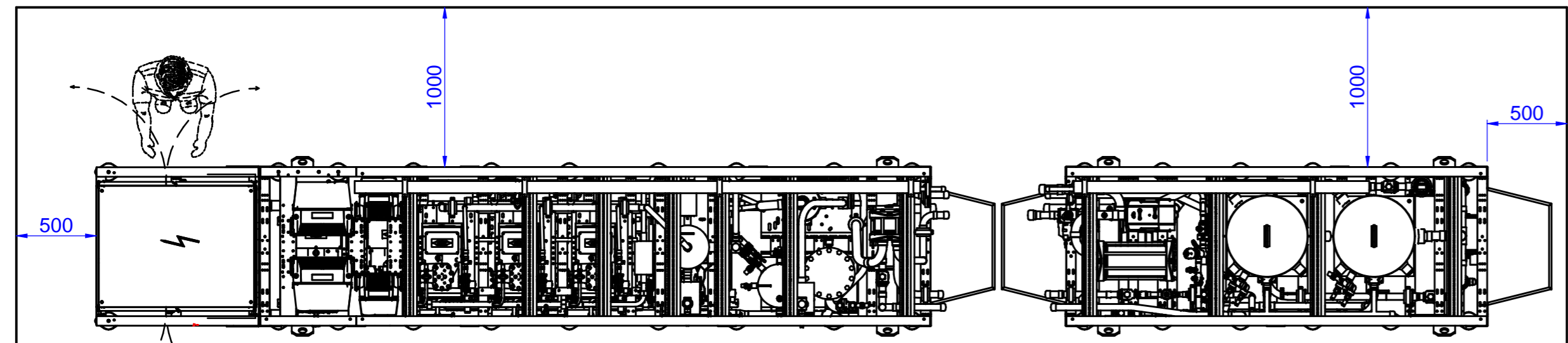

FREE FOR MAINTENANCE

B	BACINELLA RACCOGLI CONDENSA	DRIP TRAY	BAC RÉCUPÉRATION CONDENSATS	AUFFANGWANNE
D	PIEDINI ANTIVIBRANTI	ANVIBRATION FOOT	PIEDS ANTIVIBRATILES	SCHWINGUNGSDÄMPFER
M	LATO MANUTENZIONE/ESTRAZIONE COMPRESSORE	SERVICE / INSPECTION SIDE	CÔTÉ ENTRETIEN / EXTRACTION COMPRESSEURS	BEDIENUNGSSEITE
1	PANNELLI ASPORTABILI	REMOVABLE PANELS	PANEAUX REMOVIBLES	ABNEHMBARE PANELEE
2	FILTRO DI PROTEZIONE	PROTECTION FILTER	FILTRE DE PROTECTION	SCHUTZFILTER
3	PUNTI DI SOLLEVAMENTO	LIFT POINTS	POINTS DE SOULÈVEMENT	HEBESTÜTZPUNKTE
4	LATO CONNESSIONI (PER DETTAGLI VEDERE SCHEMA FRIGO)	CONNECTIONS SIDE (FOR DETAILS SEE REFRIGERATING DIAGRAM)	CÔTÉ DES CONNECTIONS (POUR PLUSIERS DÉTAILLES VOIR SCHÉMA FRIGORIFIQUE)	ANSCHLUSSESEITE (SEHEN SIE DAS FLEISILD FÜR WEITERE DETAILS)
5	ENTRATA LINEA ELETTRICA	ELECTRIC LINE INLET	ENTRÉE LIGNE ÉLECTRIQUE	ENLAß EL. ZULEITUNG
6	LATO PANNELLO PORTA STRUMENTI	INSTRUMENTS PANEL SIDE	CÔTÉ PANEAU INSTRUMENTS	INSTRUMENT TAFELSEITE
8	PROTEZIONE TUBI REMOVIBILE	REMOVABLE PROTECTION PIPES	PROTECTION TUYAUX DÉMONTABLE	RÖHRE ABNEHMBARE SCHUTZ

Rev.	Descrizione revisione	Revisionato	Data	Visto
------	-----------------------	-------------	------	-------

SCM FRIGO
 Disegnato: danieles
 Data: 23-09-22
 Nome file: DI11D053A
 Denominazione: MWT2x260+2x230(2x260ACCP)MTDX+UMCE3x050HBT
 DIMENSIONAL DRAWING
 Foglio: 1/1
 Scala: 1:10
 Peso Netto/Empty weight: Kg