

CERTIFICATE OF PLANT DESIGN REGISTRATION

Work Health & Safety Act 2011
Work Health & Safety Regulation 2011

ABN: 81 913 830 179
Phone: 13 10 50

Registration No: PV 6-211682/17

Issue Date: 4/04/2017

Registration Holder: DANFOSS A/S

Postal Address: 81 NORBORGVEJ
NORDBORG 6430
DENMARK

Plant Type: Pressure Vessel Original

Model Number/ Trade Name: SCROLL COMPRESSOR SHELL NO 3

Technical Standard : EN 14276-1:2006 + A1:2011

Engineering Principles: No

Drawing Number Design:

Design Description:

Hazard Level	C
Contents	Harmful
Chamber 1 Volume (l)	13.6
Chamber 1 Design Pressure (kPa)	0 TO 2500
Chamber 1 Temperature (°C)	-35 TO 54
Chamber 1 Fluid Type	Gas
Drawing Number & Revisions	9850280_801 REV A
Pressure Vessel	Other
Other Type	HERMETIC COMPRESSOR SHELL
Number of Chambers	1

Note: The design of an item of plant registered under the Occupational Health and Safety Regulation immediately before the repeal of that regulation is deemed to have been registered under part 5.3 of the WHS Regulation

Fee Paid: \$ 272.08

Receipt Date: 29/03/2017

Receipt No: 30-1566

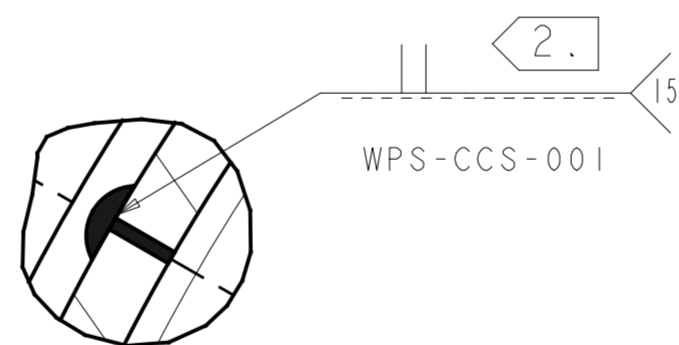
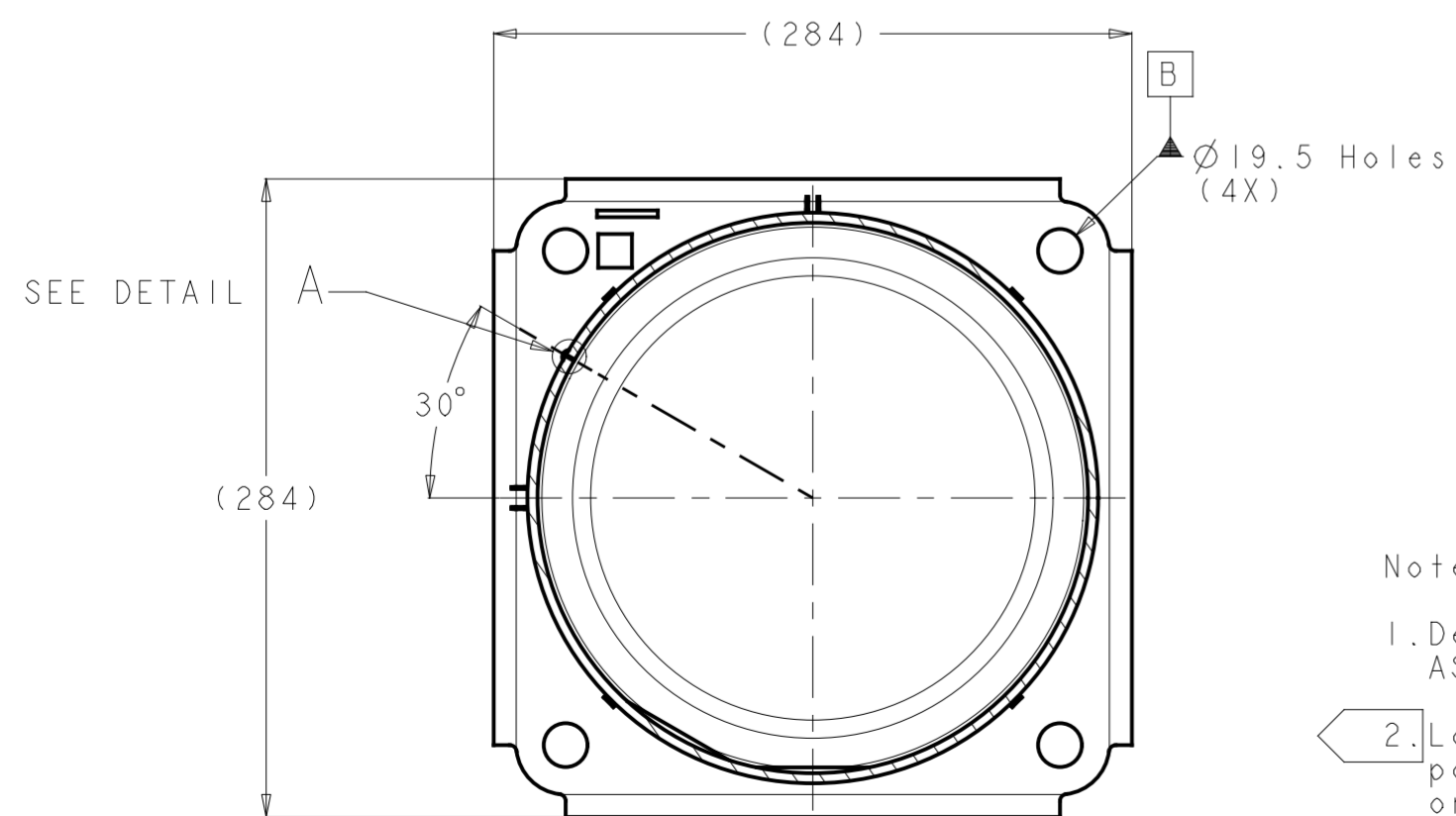
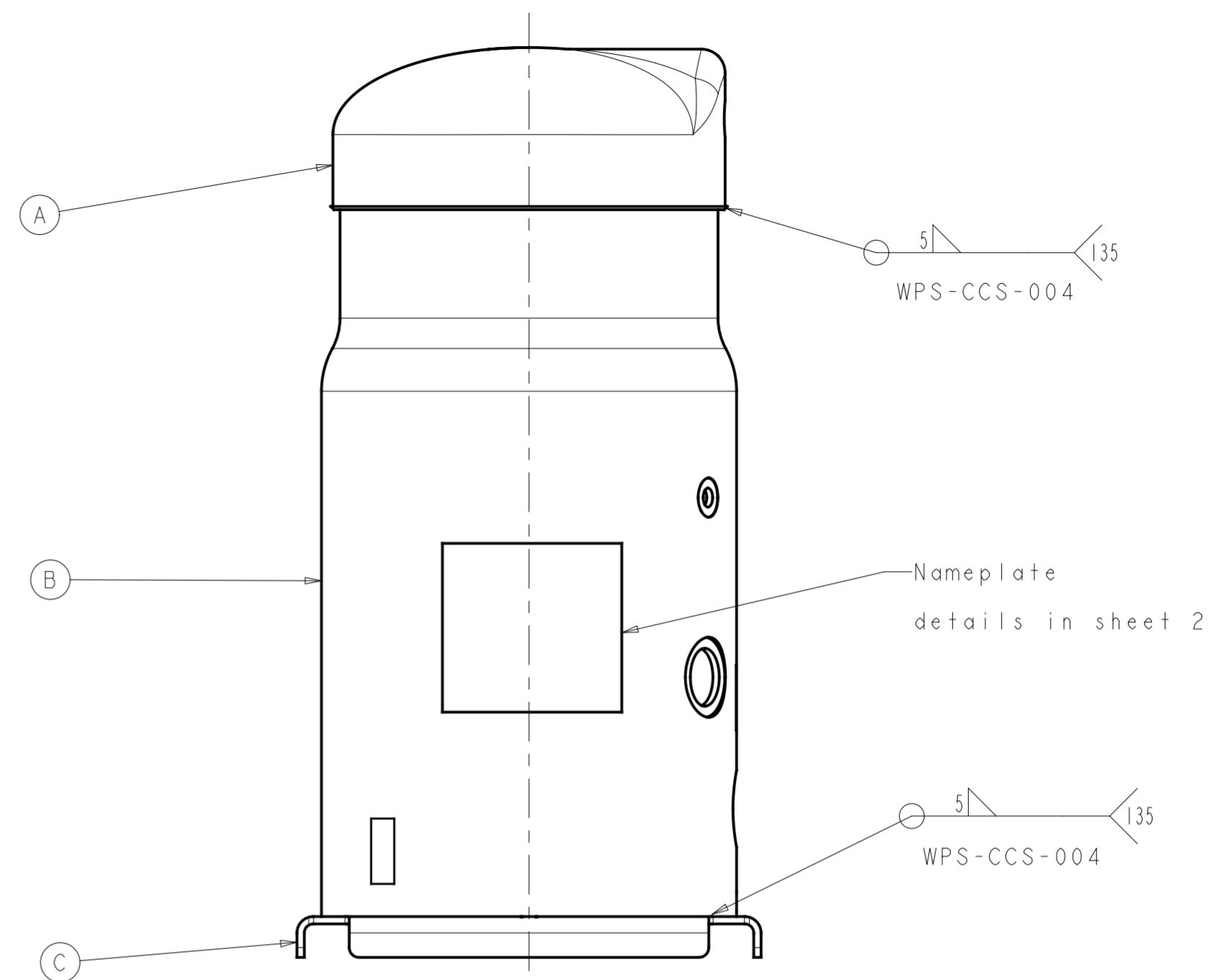
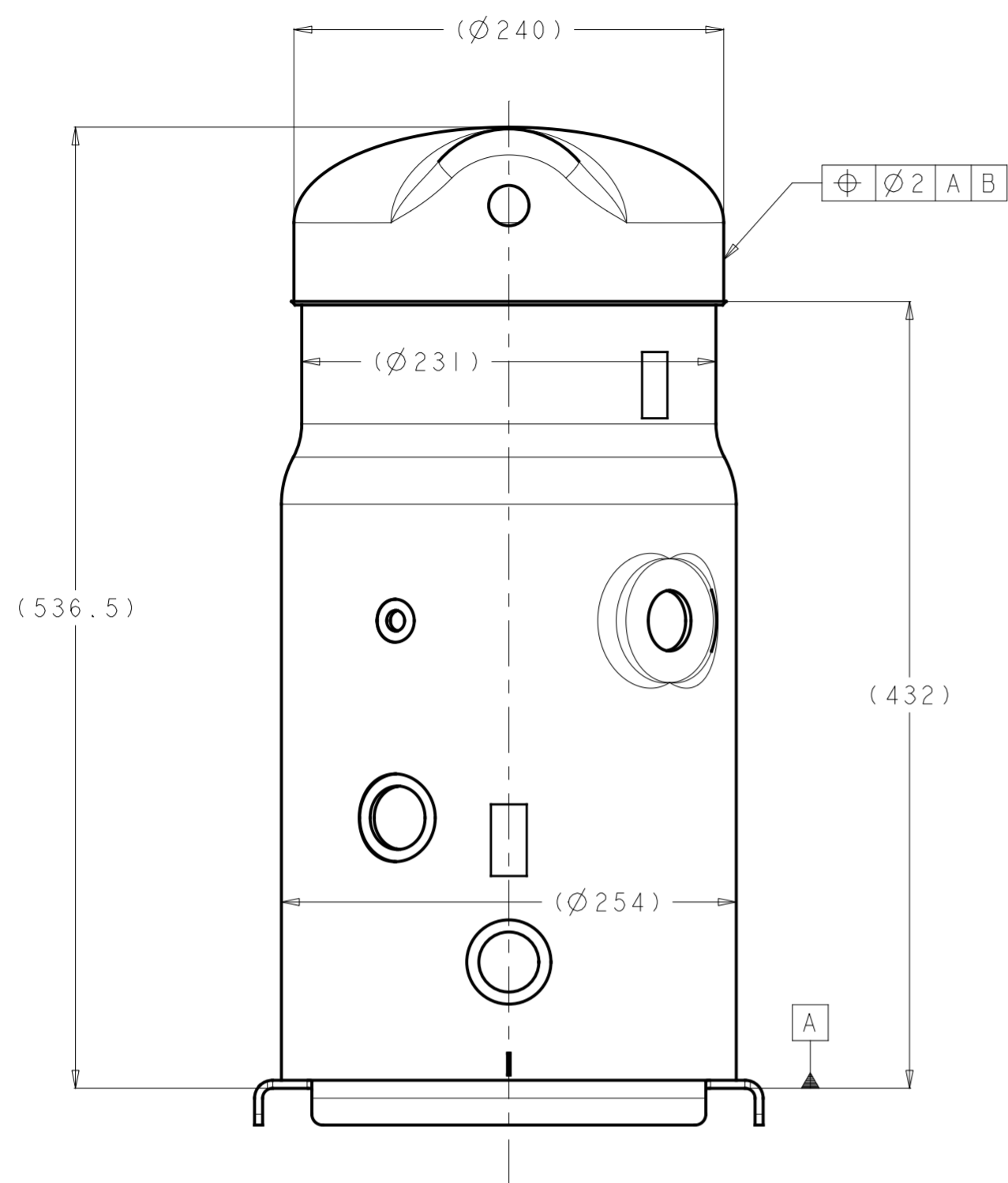

DETAIL A
SCALE 2/1

Notes:

1. Design code: EN13445, EN14276-1, AS4343: Hazard level C.
2. Longitudinal continuous welding, without porosities, with a full penetration or welding with a bead visible inside the shell.
3. Compressor Model: SM110, SZ110, SM120, SZ120

	Pressure (bars)	Volume(L)	TSMX (°C)	TSMI (°C)
Lower Pressure	25	13.6	54	-35
High Pressure	31.9	1.1	150	-35

Model	Part	description	Drawing No.	Thickness MIN.	Material Grade	Material Standard
SZ120	A	upper shell	5312387	3.2mm	SPHC	Q/BQB 302
	B	mid shell	5312379	3.0mm	SPHE	Q/BQB 302
	C	lower shell	5312369	4.0mm	SPHC	Q/BQB 302

General Tolerances Table	Drawing Status : Preliminary			Surface Area (m ²) Estimated Mass (Kg) Projection Scale Size 1/5 A2	Key characteristic Critical characteristic According to Danfoss standard 50220024 Material : - Designation Scroll Compressor Shell No.3
	Creation 10-10-2016 Revision ECR Number Date Designer Wu Fang Approval Kong Haili				
Confidential: Property of Danfoss Commercial Compressors. Not to be handed over to copied or used by third party. Two or three dimensional reproduction of contents to be authorized by Danfoss CC.				Sheet 1 of 2 A Dwg N° 9850280 801 A	

SECTION A-A



Nameplate

General Tolerances Table	Drawing Status : Preliminary				▽ Key characteristic ⊕ Critical characteristic According to Danfoss standard 50220024 Material : - Designation Scroll Compressor Shell No.3
	Surface Area (m2)	Estimated Mass (Kg)	Projection	Scale	
Roughness (µm)	A	Creation	10-10-2016	Size A2	Confidential: Property of Danfoss Commercial Compressors. Not to be handed over to copied or used by third party. Two or three dimensional reproduction of contents to be authorized by Danfoss CC.
	Revision	ECR Number	Date		
	Designer	Wu Fang			
	Approval	Kong Haili			
ISO 8015 ISO 1101	Sheet 2 of 2			A	Dwg N° 9850280 801 A